



# T755H

**Pro1 Technologies**

1111 S. Glenstone Ave., Suite 3 -100  
 Springfield, MO 65804  
 Toll Free: 888-776-1427  
 Web: www.pro1iaq.com  
 Hours of Operation: M-F 9AM - 6PM Eastern

**Thermostat Application Guide**

Description	
Gas or Oil Heat	Yes
Electric Furnace	Yes
Heat Pump (No Aux. or Emergency Heat)	Yes
Heat Pump (With Aux. or Emergency Heat)	Yes
Multi-Stage Systems	Yes
Heat Only Systems	Yes
Cool Only Systems	Yes
Millivolt	Yes
Any HVAC system up to 3H/2C with standard low voltage controlled humidifier.	Yes
Any HVAC system up to 3H/2C with standard low voltage controlled de-humidifier.	Yes

**Power Type**

Battery Power  
 Hardwire (Common Wire)  
 Hardwire (Common Wire) with Battery Backup

**A trained, experienced technician must install this product.**

Carefully read these instructions. You could damage this product or cause a hazardous condition if you fail to follow these instructions.

**Table of Contents**

**Page**

Installation Tips	2-3
Thermostat Quick Reference	4-5
Wiring	6
Wiring Diagrams	7-10
Technician Setup	11-16
Setting the Humidity	17-18
Programming Thermostat	19-21
Features	22
Specifications	23

Una version en español de este manual se puede descargar en la pagina web de la compañía.

**Wall Locations**

The thermostat should be installed approximately 4 to 5 feet above the floor. Select an area with average temperature and good air circulation.

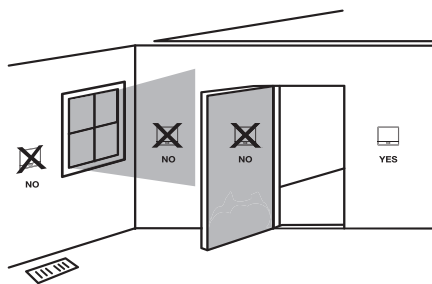

**Do not install thermostat in locations:**

- Close to hot or cold air ducts
- That are in direct sunlight
- With an outside wall behind the thermostat
- In areas that do not require conditioning
- Where there are dead spots or drafts (in corners or behind doors)
- Where there might be concealed chimneys or pipes



**Installation Tip**

Pick an installation location that is easy for the user to access. The temperature of the location should be representative of the building.

**Subbase Installation**

- ① Horizontal Mount
- ② Vertical Mount

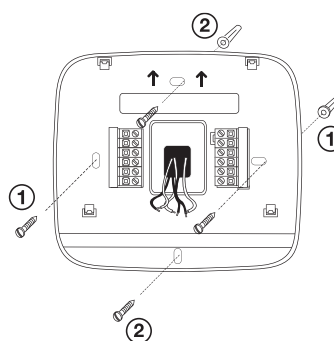

For vertical mount put one screw on the top and one screw on the bottom.  
 For horizontal mount put one screw on the left and one screw on the right.



**Installation Tip: Electrical Hazard**

Failure to disconnect the power before beginning to install this product can cause electrical shock or equipment damage.



**Mercury Notice**

All of our products are mercury free. However, if the product you are replacing contains mercury, dispose of it properly. Your local waste management authority can give you instructions on recycling and proper disposal.

1 ® U.S. Registered Trademark. Patents pending  
 Copyright © 2017 All Rights Reserved.

Rev. 1712

2

**Installation Tips**

**Mount Thermostat**

Align the 4 tabs on the subbase with corresponding slots on the back of the thermostat, then push gently until the thermostat snaps in place.

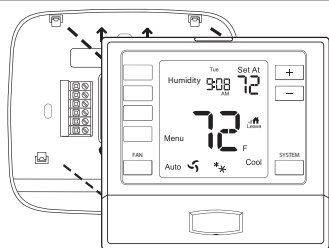

**Battery Installation**

Battery installation is recommended even if thermostat is hardwired (C terminal connected). When thermostat is hardwired and batteries are installed, the thermostat will activate a compressor delay of 5 minutes when the thermostat detects a power outage from the hardwired power supply.

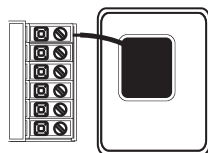

**Important:**

High quality alkaline batteries are recommended. Rechargeable batteries or low quality batteries do not guarantee a 1-year life span.

Insert 2 AA Alkaline batteries (included). High quality alkaline batteries are recommended.

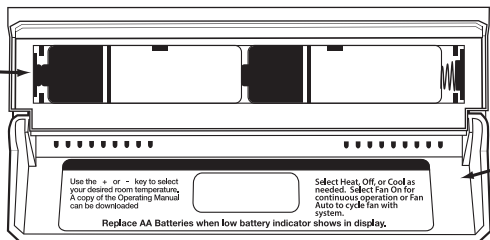

Simple operating instructions are found on the back of the battery door.

**Thermostat Quick Reference**

**Getting to know your thermostat**

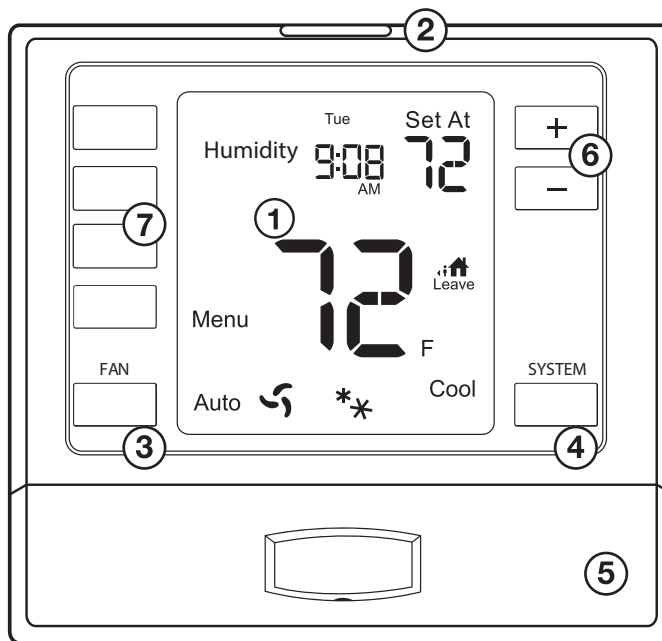

- ① LCD Display
- ② Glow in the dark light button
- ③ Fan Button
- ④ System Button
- ⑤ Easy change battery door
- ⑥ Temperature Setpoint Buttons
- ⑦ User Buttons

## Getting to know your thermostat

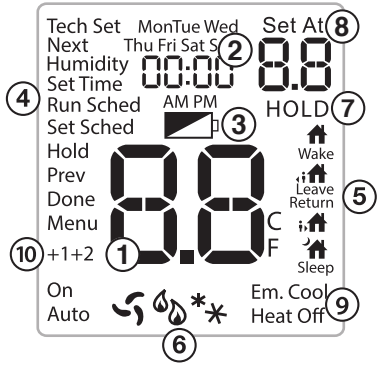

- ① Indicates the current room temperature
- ② Time and day of the week
- ③ **Low Battery Indicator:** Replace batteries when this indicator is shown.
- ④ **Menu Options:** Shows different options.
- ⑤ **Program Time Periods:** This thermostat has 4 programmable time periods per day.
- ⑥ **System Operation Indicators:** The COOL ON \*x, HEAT ON y or z icon will display when the COOL, HEAT, or z (fan) is on. **The compressor delay feature is active if these are flashing.**
- ⑦ **Hold** is displayed when the thermostat program is permanently overridden.
- ⑧ **Setpoint:** Displays the selected setpoint temperature.
- ⑨ **System:** Indicates current mode of operation.
- ⑩ **Stages:** +1 will appear in the display when second stage of heat or cool is on. +2 will appear for third stage of heat.

### Important

The low battery indicator is displayed when the AA battery power is low. If the user fails to replace the battery within 21 days, the screen will only show the low battery indicator but maintain all functionality. If the user fails to replace the batteries after an additional 21 days (days 22-42 since first "low battery" display) the setpoints will change to 55°F (Heating) and 85°F (Cooling). If the user adjusts the setpoint away from either of these, it will hold for 4 hours then return to either 55°F or 85°F. After day 63 the batteries must be replaced immediately to avoid freezing or overheating because the thermostat will shut the unit off until the batteries are changed.

## Wiring

1. If you are replacing a thermostat, make note of the terminal connections on the thermostat that is being replaced. In some cases the wiring connections will not be color coded. For example, the green wire may not be connected to the G terminal.
2. Loosen the terminal block screws. Insert wires then retighten terminal block screws.
3. Place nonflammable insulation into wall opening to prevent drafts.



**Caution:**  
**Electrical Hazard**

Failure to disconnect the power before beginning to install this product can cause electrical shock or equipment damage.



**Warning:**

All components of the control system and the thermostat installation must conform to Class II circuits per the NEC Code.

Terminal	2 Heat 2 Cool Conventional System	2 Heat 2 Cool Heat Pump System	3 Heat 2 Cool Heat Pump System
RC	Transformer power (cooling)	Transformer power (cooling)	Transformer power (cooling)
RH	Transformer power (heating)	Transformer power (heating)	Transformer power (heating)
C	Transformer common	Transformer common	Transformer common
B	Energized in heating	Heat pump changeover valve energized in heating	Heat pump changeover valve energized in heating
O	Energized in cooling	Heat pump changeover valve energized in cooling	Heat pump changeover valve energized in cooling
G	Fan relay	Fan relay	Fan relay
W/E	First stage of heat	First stage of emergency heat	First stage of emergency heat
W2	Second stage of heat	Auxiliary heat relay, second stage of heat	Auxiliary heat relay, third stage of heat
Y	First stage of cool	First stage of heat & cool	First stage of heat & cool
Y2	Second stage of cool	Second stage of cool	Second stage of cool & second stage of heat
H	Humidify	Humidify	Humidify
D	Dehumidify	Dehumidify	Dehumidify

## Wiring Diagrams

Typical 2H/2C system with 24 VAC Humidifier

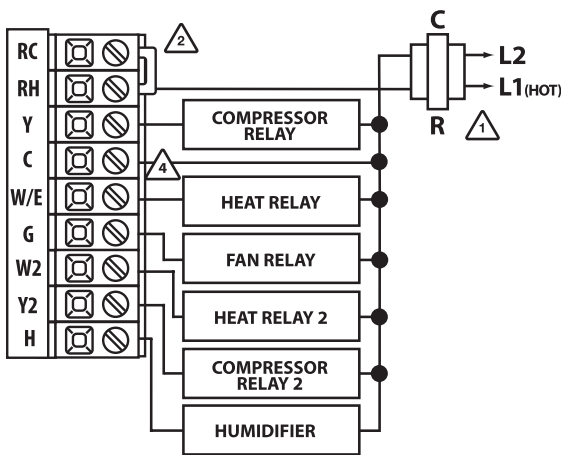

Typical 2H/2C system with Dry Contact Humidifier

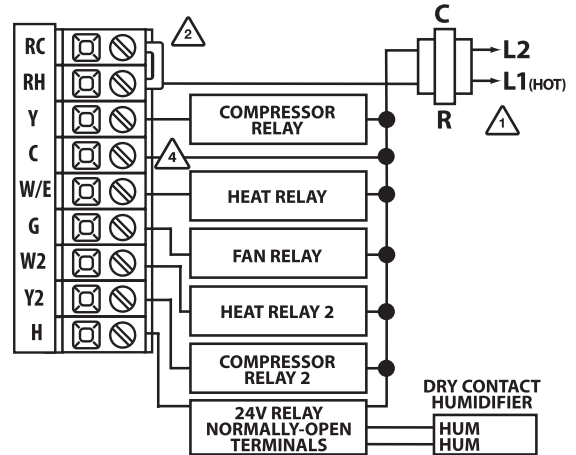

Typical 2H/2C system with Dehumidify Terminal

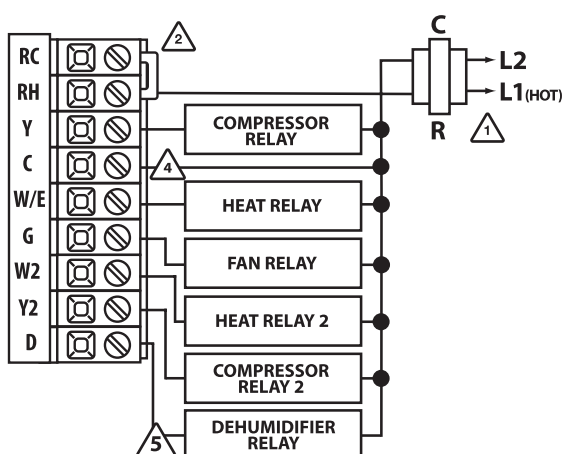

**Note:** In many heat pump systems with no emergency heat relay a jumper can be installed between E and W2.

Wiring Tips

C Terminal

The C (common wire) terminal does not have to be connected when the thermostat is powered by batteries.

Wire Specifications

Use shielded or non-shielded 18-22 gauge thermostat wire.



**Installation Tip:** Do not overtighten terminal block screws, as this can damage the terminal block. A damaged terminal block can keep the thermostat from fitting on the subbase correctly or cause system operation issues. **Max Torque = 6in-lbs.**

- 1 Power supply
- 2 Factory - installed jumper. Remove only when installing on 2 transformer systems.
- 3 Use either O or B terminals for changeover valve.
- 4 Optional 24 VAC common connection when thermostat is used in battery power mode.
- 5 If DEHUM relay requires a normally-energized input, set Dehumidify relay to NC in Technician Setup.

Typical 2H/2C System: 1 Transformer

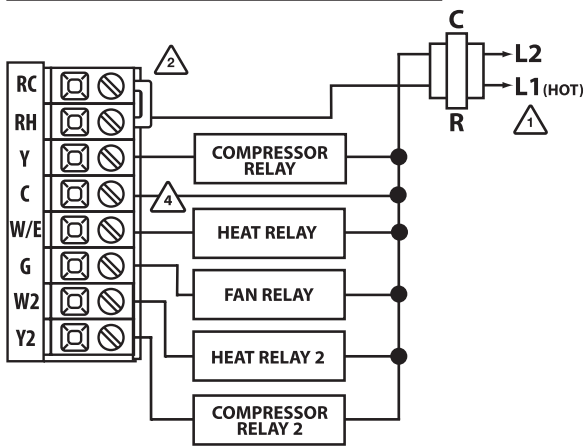

Typical 2H/2C System: 2 Transformer

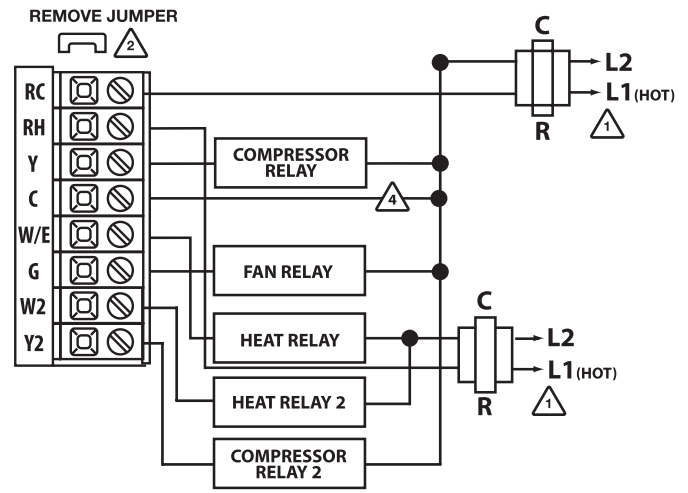

Typical 3H/2C or 2H/1C Heat Pump System

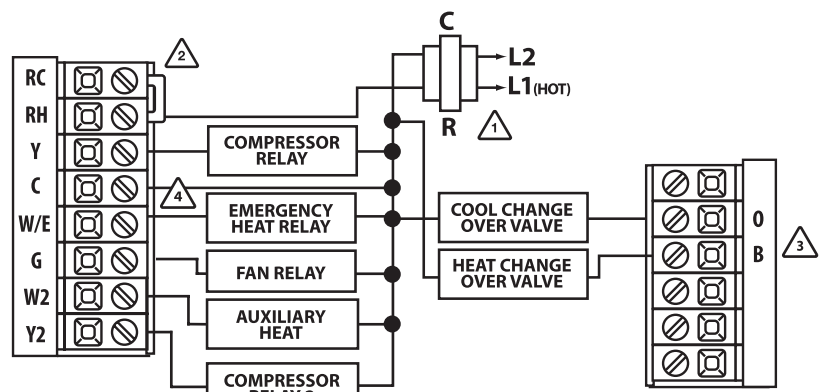

7

8

Tech Settings

Tech Settings

Technician Setup Menu

This thermostat has a technician setup menu for easy installer configuration. To setup the thermostat for your particular application:

1. Press the **MENU** button
2. Press and hold **TECH SET** button for 3 seconds. This 3 second delay is designed so that homeowners do not accidentally access the installer settings.
3. Configure the installer options as desired using the table below.

Use the **+** or **-** keys to change settings and the **NEXT STEP** or **PREV STEP** key to move from one step to another. **Note:** Only press the **DONE** key when you want to exit the Technician Setup options.

Tech Settings	LCD Will Show	Adjustment Options	Default
Filter Change Reminder	Next: SE OFF FI Prev: Done	You can adjust the filter change reminder from OFF to 2000 hours of runtime in 50 hour increments. Tap the second button from the top left side of the thermostat to display the current filter elapsed runtime.	OFF
Room Temperature Calibration	Next: CAL 0 Prev: Done	You can adjust the room temperature display to read 4° above or below the factory calibrated reading.	0
Minimum Compressor On Time	Next: COMN OF Prev: Done	You can select the minimum compressor run time from "off", "3", "4", or "5" minutes. If 3, 4, or 5 is selected, the compressor will run for at least the selected time before turning off.	OFF
Compressor Short Cycle Delay	Next: CDLY ON Prev: Done	Selecting ON will not allow the compressor to be turned on for 5 minutes after the last time the compressor was switched off. Select OFF to remove this delay.	ON

Tech Settings	LCD Will Show	Adjustment Options	Default
Cooling Swing	Next: dFCO 0.5 Prev: Done	The swing setting often called "cycle rate", "differential" or "anticipation" is adjustable. A smaller swing setting will cause more frequent cycles and a larger swing setting will cause fewer cycles.	0.5
Heating Swing	Next: dFHE 0.4 Prev: Done	The swing setting often called "cycle rate", "differential" or "anticipation" is adjustable. A smaller swing setting will cause more frequent cycles and a larger swing setting will cause fewer cycles.	0.4
Heating Setpoint Limit	HELM 90	This feature allows you to set a maximum heat setpoint value. The setpoint temperature cannot be raised above this value.	90
Cooling Setpoint Limit	COLM 44	This feature allows you to set a minimum cool setpoint value. The setpoint temperature cannot be lowered below this value.	44
Morning Recovery	Next: MORN ON Prev: Done	This feature will start heating early to bring the building temperature to its programmed setpoint by the beginning of the WAKE time period.	ON
F or C	Next: FORC OF Prev: Done	Select F for Fahrenheit temperature read out or select C for Celsius read out.	F

Swing Setting Tip

Temperature swing, sometimes called differential or cycle rate, can be customized for this individual application. For most applications choose a swing setting that is as long as possible without making the occupants uncomfortable.

11

12

Tech Settings	LCD Will Show	Adjustment Options	Default	
12 or 24 Hour Clock	You can select either a 12 or 24 hour clock setting.	Next CLOCK 12 Prev Done	Use the <b>+</b> and <b>-</b> to select 12 or 24 hour clock.	12
Fan Operation	Select GAS for systems that control the fan during a call for heat. Select ELEC to have the thermostat control the fan during a call for heat.	Next FAN GA Prev Done	GAS - GS or ELEC - EL	GAS
Program Options	You can configure this thermostat to have 7 Days, 5+1+1 programming or non programmable.	Next PROG 5d Prev Done	Use the <b>+</b> and <b>-</b> key to select 7d for 7 Day, 5d for 5+1+1, or 0d for non programmable.	5d
Heat Pump	When turned on the thermostat will operate a heat pump. 1. EM. Heat will show as an option in the system switch. 2. Y will be first stage of heat & cool, W/E will be emergency heat relay & W2 will be auxiliary heat relay.	Next HPUM OF Prev Done	<b>OFF</b> configures the thermostat for non-heat pump systems. <b>ON</b> configures the thermostat for heat pump systems.	OFF
System Switch	You can configure the system switch for the particular application: Heat - Off - Cool, Heat - Off, Cool - Off. Note: EM. Heat will show if in heat pump mode.	Next SYST Prev Done	Use the <b>+</b> or <b>-</b> key until the desired application is flashing.	Heat Off Cool
Dual Fuel Auxiliary for Heat Pump	For Dual Fuel applications (Gas/ Fossil fuel Auxiliary Heat), turn this setting <b>ON</b> to <b>LOCKOUT</b> the Heat Pump (Y) when Auxiliary Heat (W2) is on. If desired - This can also be used with Electric Auxiliary.  Will only appear if Heat pump setting is turned ON.	Next GRUW OF Prev Done	<b>OFF</b> Will allow Y(1st stage of Heat) and W2 (Aux Heat) to run together if called for. <b>ON</b> Will de-energize Y terminal 45 seconds after a call for Auxiliary Heat (W2).	OFF

Tech Settings	LCD Will Show	Adjustment Options	Default	
Stages of Heat	You can configure the thermostat to operate a 3 stage heat pump system. 2H 2C = 2 heat, 2 cool 3H 2C = 3 heat, 2 cool  This feature only shows if Technician Setup Step for HEAT PUMP is set to ON.	Next Step HPUM 2H Prev Step	Use the <b>+</b> or <b>-</b> key to change between 2H and 3H. 2H will use Y1 as first stage and W2 as auxiliary. 3H will use Y1 as first stage, Y2 as second stage and W2 as auxiliary.	2H
Cooling Fan Delay	The cooling fan delay setting will delay the fan from coming on in cool mode and keep running after the compressor shuts off for a short time to save energy in some systems.	Next Step FNDL OF Prev Step	You can select the cooling fan delay from "OFF", "15", "30", "60" or "90" seconds. If 15, 30, 60 or 90 is selected the fan will not turn on for that many seconds when there is a call for cool and will run for that many seconds after satisfying a call for cool.	OFF
Humidify	This feature adds humidity when system key is in HEAT. <i>Note: See terminal Options on page 15.</i>	Next HUMD OF Prev Done	Use the <b>+</b> and <b>-</b> key to turn on or off. If ON is selected the humidity will be displayed on the main screen and HUM terminal will energize when humidity setpoint is above ambient humidity in Heat mode.	OFF
Dehumidify	This feature removes humidity when system key is in COOL. <i>Note: See terminal Options on page 15.</i>	Next DHUM OF Prev Done	Use the <b>+</b> and <b>-</b> key to turn on or off. If ON is selected the humidity will be displayed on the main screen and DUM terminal will energize when humidity setpoint is below ambient humidity in Cool mode.	OFF
Humidity Calibration	This feature allows the installer to change the calibration of the ambient humidity displayed.	Next HCAL 0 Prev Done	Use the <b>+</b> and <b>-</b> key to adjust the calibration +/-3. Each one unit of adjustment amounts to approximately 5%.	0
Dehumidify with AC	This feature forces the A/C to run longer to remove humidity when needed. The A/C will "over cool" the room a few degrees until humidity reaches the desired setpoint.	Next DHAC NO Prev Done	Use the <b>+</b> and <b>-</b> key to select YES or NO. If selected YES allows over cooling to be used to control humidity in Cool mode. If NO is selected the system will not use over cooling.	NO

Setting the Humidity

Setting Target Humidity Setpoint

Follow the steps below to change your target humidity setpoint.

Press the **HUMIDITY** key  
Use the **+** or **-** key to select the target humidity setpoint.  
Press **DONE** when completed.

**Note:**  
The target humidity setpoint is not programmable. Unlike temperature, humidity does not change quickly and should not be programmed.

Humidity is only energized during heat. Dehumidify is only energized during cool. Heat and Cool each have their own target setpoints.

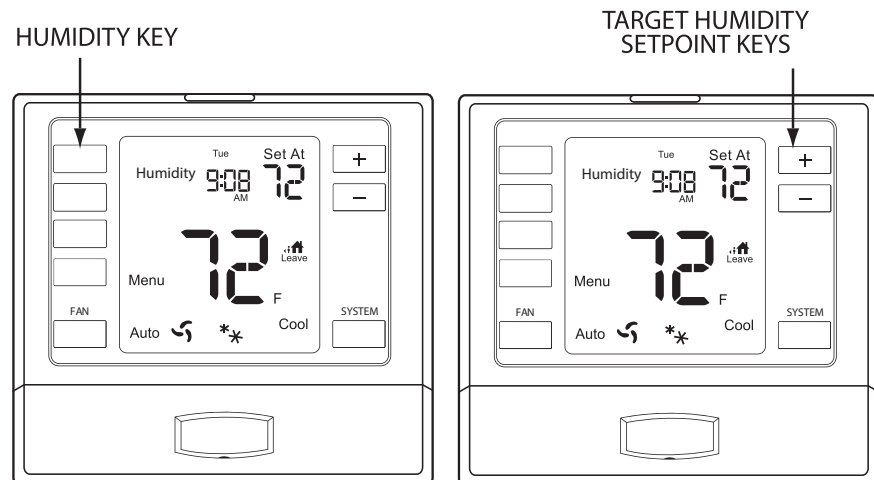

Setting the Humidity

Setting Target Humidity Setpoint

Ambient humidity will flash in the time field when Humidify or De-Humidify is set to **ON**.

**HON** will also flash when the Humidity terminal is energized. **dON** will also flash when the De-Humidify terminal is energized.

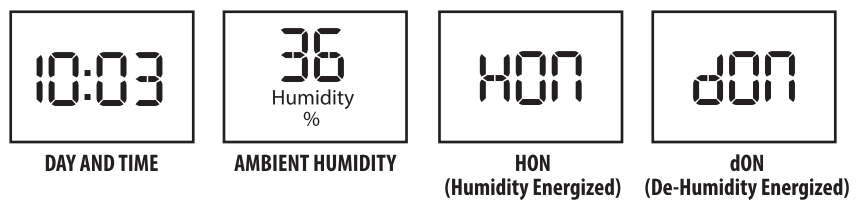

Recommended Heating Settings:

Increasing Humidity

The table on the right shows recommended indoor humidity levels in relation to outdoor temperatures during heating (adding humidity).

Recommended Cooling Settings:

Consult your professional HVAC technician for recommended settings for your climate.

Outside Temperature (0°F)	Recommended Relative Humidity
+20° and above	35% to 40%
+10°	30%
0°	25%
-10°	20%
-20°	15%

Tech Settings	LCD Will Show	Adjustment Options	Default
Over Cool Limit	Next OCCOL 3 Prev Done	Use the <b>+</b> and <b>-</b> key to select the maximum number of degrees of over cool.  Options are: 2,3,4,5	3
HUM Terminal	Next Step HTRM 1 Prev Step	Use the <b>+</b> or <b>-</b> key to select one of the four options.  View the HUM terminal chart below for an explanation of these options.	1
DHM Terminal	Next Step dTRM 1 Prev Step	Use the <b>+</b> or <b>-</b> key to select one of the four options.  View the DUM terminal chart below for an explanation of these options.	1
Dehumidify Relay	Next Step dHR NO Prev Step	Use the <b>+</b> or <b>-</b> key to select NO or NC.  If NO is selected D will energize to dehumidify.  If NC is selected D will be normally energized. D will de-energize to dehumidify.	NO

## HUM Terminal

OPTIONS	HUM terminal energizes when the ambient humidity is...
1	Below the humidity setpoint and heat or fan is energized.
2	Below the humidity setpoint and heat is energized.
3	Below the humidity setpoint. It will also energize the fan during a call for humidity.
4	Below the humidity setpoint.

## DHM Terminal

OPTIONS	DUM terminal energizes when the ambient humidity is...
1	Above the humidity setpoint and cool or fan is energized.
2	Above the humidity setpoint. It will also energize the fan during a call for dehumidify.
3	Above the humidity setpoint.
4	Above the humidity setpoint and the compressor is not running.

# Programming

## Programming

All of our programmable thermostats are shipped with an energy saving pre-program. You can customize this default program by following the steps on next page.

There are four time periods for each program (**WAKE, LEAVE, RETURN, SLEEP**).

Factory Default Program				
Day of the Week	Events	Time	Setpoint Temperature (HEAT)	Setpoint Temperature (COOL)
Weekday	Wake	6 AM	70°F (21°C)	75°F (24°C)
	Leave	8 AM	62°F (17°C)	83°F (28°C)
	Return	6 PM	70°F (21°C)	75°F (24°C)
	Sleep	10 PM	62°F (17°C)	78°F (26°C)
Saturday	Wake	6 AM	70°F (21°C)	75°F (24°C)
	Leave	8 AM	62°F (17°C)	83°F (28°C)
	Return	6 PM	70°F (21°C)	75°F (24°C)
	Sleep	10 PM	62°F (17°C)	78°F (26°C)
Sunday	Wake	6 AM	70°F (21°C)	75°F (24°C)
	Leave	8 AM	62°F (17°C)	83°F (28°C)
	Return	6 PM	70°F (21°C)	75°F (24°C)
	Sleep	10 PM	62°F (17°C)	78°F (26°C)

Tech Settings	LCD Will Show	Adjustment Options	Default
Satisfy Setpoint	Next Step S ST OF Prev Step	Use the <b>+</b> or <b>-</b> key to turn ON or OFF.	OFF
Staging Delay	Next Step SD OF Prev Step	Use the <b>+</b> or <b>-</b> key to select OFF, 10, 15, 30, 45, 60, or 90 minutes.	OFF



**Note:** Our standard staging logic, optional satisfy setpoint and optional staging delay allows for job by job customization that balances comfort, energy efficiency and equipment longevity.

# Programming

## Set Program Schedule 5+1+1 or 7 Day

To customize your program schedule, follow these steps:

1. Select **HEAT** or **COOL** with the system switch. **Note:** You have to program heat and cool each separately.
2. Press the **MENU** button (If menu does not appear first press **RUN SCHED**)
3. Press **SET SCHED**. Note: Monday-Friday or (**Monday if in 7 Day**) is displayed and the **WAKE** icon is shown. You are now programming the wake time period for that day.
4. Time is flashing. Use the **+** or **-** key to make your time selection for that day's **WAKE** time period. Note: If you want the fan to run continuously during this time period, select **ON** with the **FAN** key.
5. Press **NEXT STEP**
6. The setpoint temperature is flashing. Use the **+** or **-** key to make your setpoint selection for that day's **WAKE** time period.
7. Press **NEXT STEP**
8. Repeat steps 4 thru 7 for that day's **LEAVE** time period, **RETURN** time period, and **SLEEP** time period.



### If in 5+1+1 Programming:

Repeat steps 4 thru 8 for the Saturday + Sunday time periods.

### If using 7- Day Programming:

Use these same steps for every individual day.

**Set Time (If using programming)**

1. With system switch set to OFF, press the **MENU** button
2. Press **SET TIME**
3. Day of the week will be flashing. Use the **+** or **-** key to select the current day of the week.
4. Press **NEXT STEP**
5. The current hour is flashing. Use the **+** or **-** key to select the current hour. When using 12-hour time, make sure the correct a.m. or p.m. choice is selected.
6. Press **NEXT STEP**
7. Minutes are now flashing. Use the **+** or **-** key to select current minutes.
8. Press **DONE** when completed.

**Temporary and Permanent Hold Feature (If using programming)**

When cool or heat is turned on, the thermostat will display **HOLD** and **RUN SCHED** on the left of your screen when you press the **+** or **-** button.

**Temporary Hold:** At this time if you do nothing, the temperature will remain at this setpoint temporarily for 4 hours.

**Permanent Hold:** If you press the **HOLD** key on the left of your screen, you will see **HOLD** appear below the setpoint temperature in the display. The thermostat will now permanently stay at this setpoint and can be adjusted using the **+** or **-** keys.

**To Return to Running Schedule:** Press the **RUN SCHED** button on the left of your screen to exit either temporary or permanent hold.

**Filter Change Reminder**

If your installing contractor has configured the thermostat to remind you when the air filter needs to be changed, you will see **FILT** in the display when your air filter needs to be changed.

**Resetting the filter change reminder:** When **FILT** reminder is displayed, you should change your air filter and reset the reminder by holding down the second button from the top left side of the thermostat for 3 seconds.

**About The Private Label Badge**

All of our thermostats use the same universal magnetic badge. Visit the company website to learn more about our free private label program.

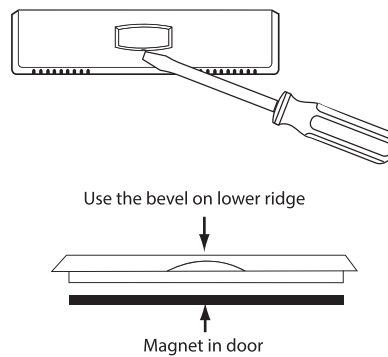

Gently slide a screwdriver into the bottom edge of the badge. Gently turn the screwdriver counter clockwise. The badge is held on by a magnet in the well of the battery door. The badge should pry off easily. **DO NOT USE FORCE.**

**Specifications**

**Specifications**

- The display range of temperature ... 41°F to 95°F (5°C to 35°C)
- The control range of temperature.... 44°F to 90°F (7°C to 32°C)
- Swing (cycle rate or differential) ..... Heating is adjustable from 0.2° to 2.0°  
Cooling is adjustable from 0.2° to 2.0°
- Power source ..... 18 to 30 VAC, NEC Class II, 50/60 Hz for hardwire  
Battery power from 2 AA Alkaline batteries
- Operating ambient ..... 32°F to +105°F (0°C to +41°C)
- Operating humidity ..... 90% non-condensing maximum
- Dimensions of thermostat ..... 4.7"W x 4.4"H x 1.1"D